

**WORKCENTERS – STORAGE ABOVE THE WORK SURFACE**



**WORKCENTERS – STORAGE ABOVE THE WORK SURFACE – WS / WM**

Whether you are installing workstations for a production or assembly line, or a custom layout for your machine tool workshop, our line of products feature an impressive selection of accessories that are sure to exceed your expectations. From shipping and receiving to your foreman's office, you will love the quality and variety of products to choose from. One of the great features of the Rousseau WM Bench Frame is that it's so easy to reconfigure — no tools required! By simply adding or rearranging accessories, it can evolve to suit your changing business needs.

You also have a choice of several work surface dimensions for each of the surfaces offered: painted steel, stainless steel, laminated wood, plastic laminate, Acrylic / PVC laminate and dissipative tops. Rousseau is your one-stop solution for an easier life!



# WORKCENTERS – STORAGE ABOVE THE WORK SURFACE

## THE ROUSSEAU DIFFERENCE

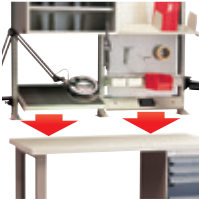

From top to bottom, you will find a Rousseau solution for even the most specialized requirements.



Easy and tool-free reconfiguration means that your workstation can evolve in line with your needs.



With our vast range of standard accessories, you can build a highly personalized workcenter.



Our WM frames can be installed on most industrial workbenches available on the market. The six fixing zones mean limited interference and endless possibilities.

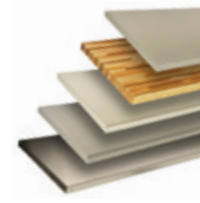

Choose from a variety of work surfaces for specific applications.

## GENERAL DIMENSIONS

WIDTH × HEIGHT ABOVE

RISER SHELVES

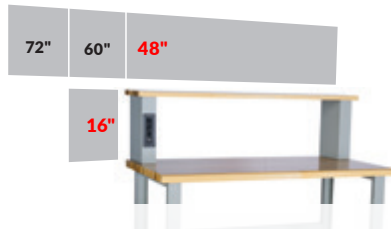

WM BENCH FRAMES

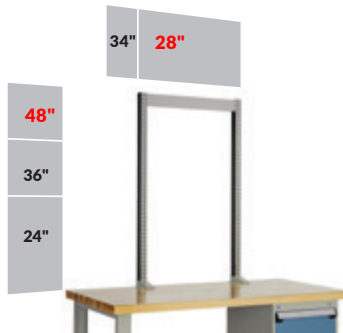
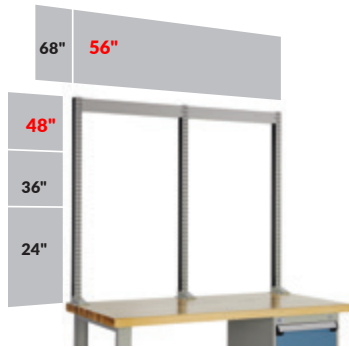

WSC2018



LC6003



LC3125C

NOTE Popular dimensions are shown in red.

# PRECONFIGURED MODELS

## WORKBENCHES WITH RISER SHELVES

### BASIC ELECTRONIC WORKBENCH



WSA4073

- 1 top of your choice
- 2 legs, 27"D × 32"H
- 1 back stop
- 1 stringer
- 1 pair of risers with power outlets on each riser
- 1 shelf, 12"D, same material as the top
- 1 shelf back

DIMENSIONS			TYPE OF TOP		
W	D	H	LAMINATED HARDWOOD	PLASTIC LAMINATE	DISSIPATIVE
60"	30"	34"	WSA2073	WSA3073	WSA4073
72"	30"	34"	WSA2074	WSA3074	WSA4074
72"	36"	34"	WSA2075	WSA3075	WSA4075

NOTE: Models with dissipative tops include 1 grounding block, 1 grounding cord and 1 grounding wrist strap, [see page 159](#).

### ELECTRONICS WORKBENCH WITH COMPACT CABINET



LG4104C

- 1 top of your choice
- 1 leg, 27"D × 32"H
- 1 L Compact Cabinet with 4" base
- 1 back stop
- 1 pair of risers with power outlets on each riser
- 1 shelf, 12"D, same material as the top
- 1 shelf back

DIMENSIONS			TYPE OF TOP		
W	D	H	LAMINATED HARDWOOD	PLASTIC LAMINATE	DISSIPATIVE
60"	30"	34"	LG2104C	LG3104C	LG4104C
72"	30"	34"	LG2105C	LG3105C	LG4105C
72"	36"	34"	LH2106C	LH3106C	LH4106C

NOTE: Models with dissipative tops include 1 grounding block, 1 grounding cord and 1 grounding wrist strap, [see page 159](#).

## WORKBENCHES WITH WM BENCH FRAMES

### ELECTRONICS WORKSTATION

LC3002C



LC3002C

- 1 double WM bench frame
- 2 tiltable shelves
- 2 plastic bin rails
- 1 power outlet module
- 1 monitor tray with arm
- 1 tiltable pan
- 1 storage cabinet with door
- 1 pair of cantilever overhead supports
- 1 overhead LED workstation light
- 7 partial dividers (4 inside storage cabinet)
- 5 plastic bins
- 1 lamp with magnifier and LED light
- 1 adapter for lamp or light-duty arm
- 1 leg, 27"D × 32"H
- 1 L Compact Cabinet with 4" base
- 1 dissipative top
- 1 grounding block
- 1 ground wrist strap

DIMENSIONS			TYPE OF TOP
W	D	H	DISSIPATIVE TOP
60"	30"	82"	LC3002C

## BASIC WORKSTATION

WSC0133



WSC0133

- 1 single WM frame
- 2 tiltable shelves
- 2 plastic bin rails
- 1 vertical adapter for power outlet strip and pneumatic connection
- 1 power outlet strip
- 6 partial dividers
- 5 plastic bins
- 2 legs, 27"D×32"H
- 1 stringer
- 1 painted steel top

DIMENSIONS			TYPE OF TOP
W	D	H	PAINTED STEEL TOP
60"	30"	82"	WSC0133

## PACKAGING STATION

WSM0006



WSM0006

- 2 multi-purpose uprights
- 2 steel shelves
- 2 structural shelf supports
- 6 sliding dividers
- 1 vertical adapter for power outlet strip and pneumatic connection
- 1 power outlet strip
- 1 document holder with arm
- 2 legs, 27"D×32"H
- 1 stringer
- 1 laminated hardwood top
- 1 paper and cardboard spool support
- 2 leg crossbars

DIMENSIONS			TYPE OF TOP
W	D	H	LAMINATED HARDWOOD
60"	30"	82"	WSM0006

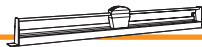

**SOLD SEPARATELY**

Packaging Shear Cutter WM87-01  
See page 138, for product details

## END-OF-AISLE WORKSTATION

WSM0017



WSM0017

- 2 closed legs, 27"D×32"H
- 1 laminated hardwood top
- 1 sliding keyboard tray (WS90-01) or adjustable keyboard tray (WS90-02) (except on model without keyboard tray [WSM0018])
- 1 single WM frame
- 2 tiltable shelves
- 6 partial dividers
- 1 power outlet strip
- 1 vertical adapter for power outlet strip and pneumatic connection
- 1 document holder with arm
- 1 tackboard / whiteboard
- 1 panel bracket kit
- 2 leg crossbars

DIMENSIONS			KEYBOARD TRAY		
W	D	H	WS90-01 SLIDING	WS90-02 ADJUSTABLE	WITHOUT KEYBOARD TRAY
36"	30"	82"	WSM0016	WSM0017	WSM0018



# PRECONFIGURED MODELS

## QUALITY CONTROL WORKSTATION

LC3003C



LC3003C

- 1 single WM bench frame
- 1 tiltable shelf
- 1 overhead LED workstation light
- 1 pair of cantilever overhead supports
- 1 power outlet module
- 1 LCD monitor and keyboard arm
- 1 tackboard / whiteboard
- 1 panel bracket kit
- 3 partial dividers
- 1 leg, 27"D×32"H
- 1 L Compact Cabinet with 4" base
- 1 plastic laminate top

DIMENSIONS			TYPE OF TOP
W	D	H	PLASTIC LAMINATE
60"	30"	82"	LC3003C

## ASSEMBLY WORKSTATION

LC3001C



LC3001

- 1 double WM bench frame
- 2 plastic bin rails
- 1 vertical adapter for power outlet strip and pneumatic connection
- 1 power outlet strip
- 1 document holder with arm
- 1 utility panel
- 2 panel bracket kits
- 1 tackboard / whiteboard
- 1 overhead LED workstation light
- 1 pair of cantilever overhead supports
- 1 tool rail
- 1 balancer trolley
- 1 tool balancer
- 5 plastic bins
- 1 pack of 10 double back single hooks
- 2 legs, 27"D×32"H
- 1 drawer unit
- 2 compact drawers, 3"H
- 1 plastic laminate top
- 1 stringer

DIMENSIONS			TYPE OF TOP
W	D	H	PLASTIC LAMINATE
60"	30"	82"	LC3001



## REPAIR AND MAINTENANCE WORKSTATION

LC2105L3C



LC2105L3C

- 1 double WM bench frame
- 1 tiltable shelf
- 1 power outlet module
- 2 partial dividers
- 1 storage cabinet with door
- 1 plastic bin rail
- 3 plastic bins
- 1 tackboard / whiteboard
- 1 panel bracket kit
- 1 leg, 27"D × 32"H
- 1 L compact cabinet with 4" base
- 1 laminated hardwood top
- 1 utility panel
- 1 screwdriver holder
- 1 pliers holder

DIMENSIONS			TYPE OF TOP
W	D	H	LAMINATED HARDWOOD
60"	30"	82"	LC2105L3C

## LABELING WORKSTATION

LC2109L3C



LC2109L3C

- 1 double WM bench frame
- 1 tiltable shelf
- 1 power outlet module
- 6 plastic bins
- 1 tackboard / whiteboard
- 1 panel bracket kit
- 3 partial dividers
- 1 leg, 27"D × 32"H
- 1 L compact cabinet with 4" base
- 1 laminated hardwood top
- 2 plastic bin rails
- 2 wire spool holders
- 1 pair of cantilever overhead supports
- 1 overhead LED workstation light

DIMENSIONS			TYPE OF TOP
W	D	H	PLASTIC LAMINATE
60"	30"	82"	LC2109L3C

## DOUBLE WORKSTATION

LC2201L3C



LC2201L3C

- 1 double WM bench frame
- 2 tiltable shelves
- 2 power outlet modules
- 16 plastic bins
- 4 partial dividers
- 2 legs, 27"D × 32"H
- 2 L compact cabinets with 4" base
- 2 laminated hardwood tops
- 6 plastic bin rails
- 2 wire spool holders
- 2 pairs of cantilever overhead supports
- 2 overhead LED workstation lights
- 1 tackboard / whiteboard
- 1 panel bracket kit
- 2 tool holders
- 2 LCD monitor, keyboard and mouse arm kits

DIMENSIONS			TYPE OF TOP
W	D	H	LAMINATED HARDWOOD
60"	60"	82"	LC2201L3C

# PRECONFIGURED MODELS

## BASIC WORKSTATION WITH R HEAVY-DUTY CABINET

R5WH5-2005



R5WH5-2005

- 1 heavy-duty cabinet (with drawer compartments)
- 1 leg, 27"D×32"H
- 1 laminated hardwood top
- 2 storage cabinets with double integrated doors
- 2 WM brackets for storage cabinet
- 1 double WM bench frame

DIMENSIONS			TYPE OF TOP
W	D	H	LAMINATED HARDWOOD
60"	30"	82"	R5WH5-2005

## ASSEMBLY WORKSTATION WITH R HEAVY-DUTY CABINET

R5WH5-2003



R5WH5-2003

- 1 heavy-duty cabinet (with drawer compartments)
- 1 laminated hardwood top
- 1 leg, 27"D×32"H
- 1 double WM bench frame
- 1 tiltable shelf
- 2 partial dividers
- 1 vertical adapter for power bar and pneumatic connection
- 1 power outlet strip
- 1 steel shelf
- 1 pair of structural shelf supports
- 1 privacy panel
- 1 panel bracket kit
- 1 panel for plastic bins
- 7 plastic bins

DIMENSIONS			TYPE OF TOP
W	D	H	LAMINATED HARDWOOD
60"	30"	82"	R5WH5-2003

## MAINTENANCE WORKSTATION WITH R HEAVY-DUTY CABINETS

R5WL5-2003



R5WL5-2003

- 2 heavy-duty cabinets (with drawer compartments)
- 1 laminated hardwood top
- 2 steel shelves
- 2 adapters for WS50 shelf
- 1 double WM bench frame
- 1 pair of cantileveroverhead supports
- 1 overhead LED workstation light
- 1 tool rail
- 1 balancer trolley
- 1 tool balancer
- 2 plastic bin rails
- 1 tool holder
- 4 plastic bins
- 1 power outlet module
- 1 tiltable pan
- 2 tiltable shelves
- 4 partial dividers
- 2 storage cabinets with door
- 1 document holder with arm
- 1 LCD monitor and keyboard arm

DIMENSIONS			TYPE OF TOP
W	D	H	LAMINATED HARDWOOD
72"	30"	82"	R5WL5-2003

# COMPONENTS – STRUCTURE ABOVE THE WORK SURFACE

## RISER SHELVES

### PAINTED STEEL SHELF

WS50



- Thickness: 1¼"
- Compatible with all riser shelf supports
- Actual width = nominal width – 3¼"

### LAMINATED HARDWOOD SHELF

WS51



- Made from varnished hardwood slats
- Thickness: 1¼"
- Compatible with WS54, WS55, WS59 and WM27-1202 riser shelf supports
- Attractive appearance

### PLASTIC LAMINATE SHELF

WS52



- Colors: Default is white. Add -BA for black or -GB for gray to the end of the product number
- Thickness: 1¼"
- Compatible with WS54, WS55, WS59 and WM27-1202 riser shelf supports
- Attractive appearance



### DISSIPATIVE SHELF

WS53



- Dissipates electrical charges that can damage electronic components
- The resistance point to point and point to ground is between 10<sup>6</sup>Ω and 10<sup>9</sup>Ω
- Color: white
- Thickness: 1¼"
- Compatible with WS54, WS55, WS59 and WM27-1202 riser shelf supports

### STAINLESS STEEL SHELF

WS56



- Thickness: 1¼"
- #4 brushed finish
- Compatible with all riser shelf supports
- Actual width = nominal width – 3¼"

### RESISTANT ACRYLIC / PVC LAMINATE SHELF

WS57



- Color: gray
- Thickness: 1¼"
- Compatible with WS54, WS55, WS59 and WM27-1202 riser shelf supports

#### DIMENSIONS

#### TYPE OF SHELF

W	D	PAINTED STEEL	LAMINATED HARDWOOD	PLASTIC LAMINATE	DISSIPATIVE	STAINLESS STEEL	ACRYLIC / PVC LAMINATE
48"	12"	WS50-4812 *	WS51-4812	WS52-4812-__	WS53-4812	WS56-4812	WS57-4812
60"	12"	WS50-6012 *	WS51-6012 *	WS52-6012-__ *	WS53-6012 *	WS56-6012	WS57-6012 *
72"	12"	WS50-7212 *	WS51-7212 *	WS52-7212-__ *	WS53-7212 *	WS56-7212	WS57-7212 *

NOTE: \* Stock items. Other models are only available according to manufacturing schedules.

### RISER SHELF SUPPORTS

WS54

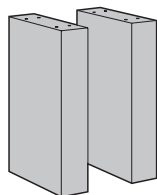

- Sold in pairs
- Compatible with WS50 (12"D), WS51, WS52, WS53, WS56 and WS57 shelves
- Height: 16"
- Attractive appearance

PRODUCT NO.	W × D × H
WS54-1602	3½" × 10¼" × 16"

### RISER SHELF SUPPORTS WITH POWER OUTLETS ON BOTH SIDES

WS55

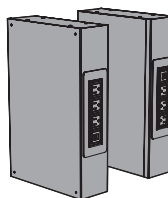

- Sold in pairs
- Each support includes either three 12A outlets for 15A circuit or three 12A outlets for 15A circuit with two USB ports
- Compatible with WS50 (12"D), WS51, WS53, WS56 and WS57 shelves
- Dimensions: 3½"W × 10¼"D × 16"H
- Attractive appearance

PRODUCT NO.	OPTIONS
WS55-161002	3 power outlets (12A)
WS55-161202	3 power outlets (12A), 2 USB ports



# COMPONENTS – STRUCTURE ABOVE THE WORK SURFACE

## RISER SHELF SUPPORTS WITH POWER OUTLETS ON ONE SIDE

WS59

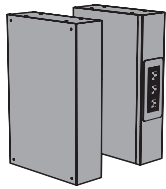

- Sold in pairs
- One support includes either three 12A outlets for 15A circuit or three 12A outlets for 15A circuit with two USB ports
- Compatible with WS50 (12"D), WS51, WS53, WS56 and WS57 shelves
- Dimensions: 3½"W × 10 ¼"D × 16"H
- Attractive appearance

PRODUCT NO.	OPTIONS
WS59-161002	3 power outlets (12A)
WS59-161202	3 power outlets (12A), 2 USB ports



WSC2020

## ECONO RISER SHELF SUPPORTS

WS82

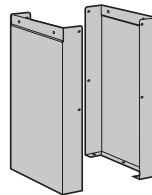

- Sold in pairs
- Can support one or two 12"D shelves
- Compatible with WS50 and WS56 shelves only
- Total height: 16"
- Mid-height shelf: 8"
- Easy to assemble

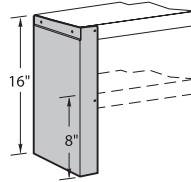

PRODUCT NO.	HEIGHT
WS82-1601	16"

## SHELF BACK OR FRONT STOP

WS58 / WS99

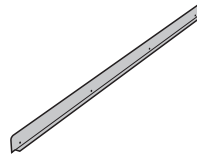

- Painted steel: WS58
- Stainless steel: WS99
- Compatible with WS50, WS51, WS52, WS53, WS56 and WS57 shelves
- Prevents objects from falling from riser shelves
- Extends above shelf by 1"
- To order: Specify the type of steel required: WS58 for painted steel and WS99 for stainless steel
- To order a WS99 in stainless steel, add 01 to the product number for installation at the back of the shelf and 02 for installation at the front

PRODUCT NO.	W × H	FOR SHELF
WS__-48__	45"W × 2¼"H	48" W
WS_-60__	57"W × 2¼"H	60" W
WS__-72__	69"W × 2¼"H	72" W

## BACK PANEL FOR RISER SHELF

WS83 / WS93

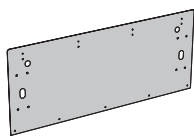

- Painted steel: WS83
- Stainless steel: WS93
- Installs behind the work surface and riser shelf
- Compatible with all types of top and shelf
- Includes holes for running cables through
- Height: 20"
- Extends above the riser shelf to prevent objects from falling
- To order: Specify the type of steel required, e.g., WS83-4616 for painted steel

PRODUCT NO.	WIDTH
WS_-4816	48"
WS_-6016	60"
WS_-7216	72"

## LED LIGHT FOR RISER SHELF

WS7A

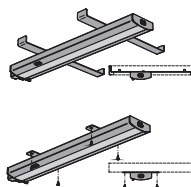

- Brightens shaded areas under riser shelves
- Emits a brighter light than fluorescent tubes and is more energy efficient
- Color temperature: 6000-7000K (cool)
- Includes a 10' power cord
- Installs under the riser shelf
- Two different galvanized steel adapters available:
  - Adapter 01 for WS51, WS52, WS53 and WS57 shelves
  - Adapter 02 for WS50 and WS56 shelves
- To order: Specify the adapter number required: 01 or 02

PRODUCT NO.	WIDTH	SHELF WIDTH
WS7A-1812__	18"	48"W and over
WS7A-2412__	24"	48"W and over
WS7A-3612__	36"	48"W and over
WS7A-4812__	48"	60"W and over
WS7A-6012__	60"	72"W and over

## WM BENCH FRAME

### MULTI-PURPOSE UPRIGHT

WM10

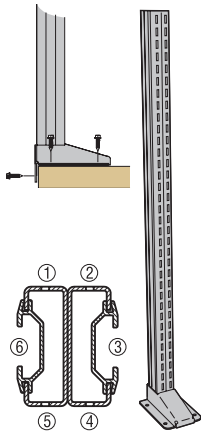

- Compatible with most workbench tops available on the market. Requires a good quality top at least 1½" thick
- Distinctive shape and industry-leading rigidity
- Includes six fixing zones to minimize interference between components
- Perforated on the front and back faces in 1" increments c/c for optimal placement of accessories ①②④⑤
- Includes two black aluminum extrusions on the sides for fine-tuned accessory placement ③⑥
- Five anchor points on the foot provide optimal stability on the two main axes
- Symmetrical front and back so the upright can be used for back-to-back workstations
- The 48"H version is ideal for overhead accessories

PRODUCT NO.	HEIGHT
WM10-24	24"
WM10-36	36"
WM10-48	48"

### WM BENCH FRAME

WM11

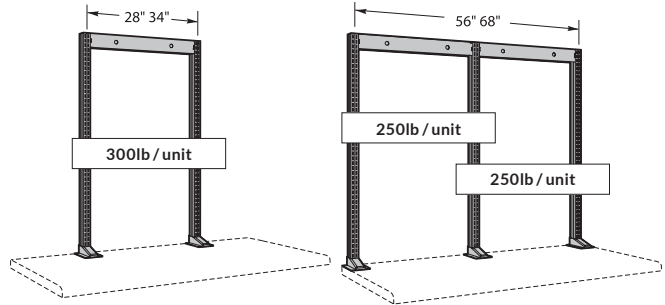

#### The single frame includes:

- 2 WM10 uprights
- 1 WM15 upright crossmember
- Load capacity: 300lb. per unit

PRODUCT NO.	W×H	WIDTH REQUIRED
WM11-2836	28"×36"	36" min.
WM11-2848	28"×48"	36" min.
WM11-3436	34"×36"	48" min.
WM11-3448	34"×48"	48" min.

#### The double frame includes:

- 3 WM10 uprights
- 2 WM15 upright crossmembers
- Load capacity: 250lb. per unit (500lb. total)

PRODUCT NO.	W×H	WIDTH REQUIRED
WM11-5636	56"×36"	60" min.
WM11-5648	56"×48"	60" min.
WM11-6836	68"×36"	72" min.
WM11-6848	68"×48"	72" min.

### TOP FLANGE FOR WM11 FRAME – 34" C/C WS1A/WS91

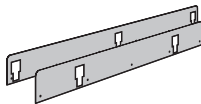

- Painted steel: WS1A
- Stainless steel: WS91
- Designed specifically to be compatible with the 34"W single or double WM frame
- Compatible with all types of top
- Height: 5" Extends above top by approx. 3¼"
- Designed to be centered on the frame
- To order: Specify the type of steel required, e.g., WS1A-480502 for a 34"W top flange for WM frame in painted steel with two uprights

PRODUCT NO.	WIDTH	APPLICATION
WS__-480502	48"	For 2 WM uprights
WS__-600502	60"	For 2 WM uprights
WS__-720502	72"	For 2 WM uprights
WS__-720503	72"	For 3 WM uprights

### UPRIGHT CROSSMEMBER

WM15

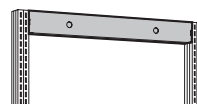

- Strengthens WM frames
- Hooks onto WM10 uprights and can be secured in place
- Includes two knockouts for pneumatic connections

PRODUCT NO.	WIDTH (C/C)
WM15-28	28"
WM15-34	34"
WM15-56	56"
WM15-68	68"

### TOP FLANGE FOR WM11 FRAME – 28" C/C

WS18/WS98

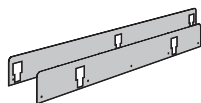

- Painted steel: WS18
- Stainless steel: WS98
- Designed specifically to be compatible with the 28"W single or double WM bench frame
- Compatible with all types of top
- Height: 5" Extends above top by approx. 3¼"
- Designed to be centered on the frame
- To order: Specify the type of steel required, e.g., WS18-480502 for a 28"W top flange for WM frame in painted steel with two uprights

PRODUCT NO.	WIDTH	APPLICATION
WS__-360502	36"	For 2 WM uprights
WS__-480502	48"	For 2 WM uprights
WS__-600502	60"	For 2 WM uprights
WS__-600503	60"	For 3 WM uprights
WS__-720502	72"	For 2 WM uprights
WS__-720503	72"	For 3 WM uprights

# COMPONENTS – STRUCTURE ABOVE THE WORK SURFACE

## SHELF

WS50 / 51 / 52 / 53 / 56 / 57



- Installs on WM uprights with WM27 riser shelf supports
- 200lb. load capacity
- Compatible with WS58 / WS99 shelf back or front stop
- Thickness: 1 ¼"

PRODUCT NO.	W × D	TYPE OF SHELF
WS50-6012	56¾" × 12"	Steel
WS51-6012	60" × 12"	Laminated hardwood
WS52-6012	60" × 12"	Plastic laminate
WS53-6012	60" × 12"	Dissipative
WS56-6012	56¾" × 12"	Stainless steel
WS57-6012	60" × 12"	Acrylic / PVC
WS50-7212	68¾" × 12"	Steel
WS51-7212	72" × 12"	Laminated hardwood
WS52-7212	72" × 12"	Plastic laminate
WS53-7212	72" × 12"	Dissipative
WS56-7212	68¾" × 12"	Stainless steel
WS57-7212	72" × 12"	Acrylic / PVC

NOTE: Available colors for WS52:



## TILTABLE SHELF

WM20

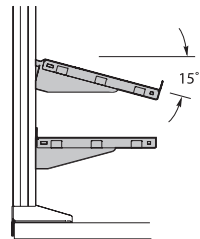
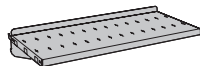

- Hooks onto WM uprights
- Includes slots spaced 2" apart c/c for installing SH52 dividers
- Includes two side brackets which can be placed at right angles or at a 15° angle
- Shelf is reversible and the edge can be used as a back stop or support for plastic bins or, if used with a 12"D shelf, as a support for ring binders
- Load capacity: 100lb. (evenly distributed)

PRODUCT NO.	W × D
WM20-2808	28" × 8"
WM20-2812	28" × 12"
WM20-3408	34" × 8"
WM20-3412	34" × 12"

## TILTABLE PAN

WM22

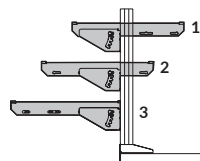
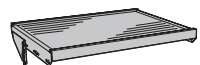

- Hooks onto WM uprights
- Three positions available: front, center or back
- Tilts from 0 to 30° with five easily adjustable positions
- Includes a full-size ribbed mat
- Usable surface area: 24½" × 18½" (28" × 20")
- Usable surface area: 30½" × 18½" (34" × 20")
- 200lb. capacity.

PRODUCT NO.	W × D
WM22-2820	28" × 20"
WM22-3420	34" × 20"

## TOP REINFORCER

WM14

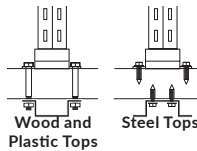
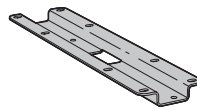

- Required for work tops less than 1½" thick or in poor condition, and for back-to-back workstations
- Strengthens the anchor points of the WM upright
- Secures to the underside of the work surface

PRODUCT NO.	W × D	COLOR
WM14-01	4" × 16"	Black



## CANTILEVER OVERHEAD SUPPORTS

WM18



- Sold in pairs
- Hooks onto WM uprights
- Locks in place via a safety latch on the top of the support
- Load capacity: designed to hold a WM45 / WM43 overhead workstation light and one WM47 tool rail, or two WM47 tool rails

PRODUCT NO.	DEPTH	COLOR
WM18-26	26"	Black

## STRUCTURAL SHELF SUPPORTS

WM27

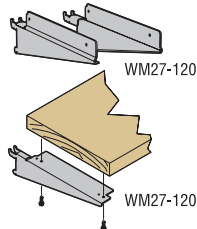

- Sold in pairs
- Hooks onto WM uprights
- Compatible with all types of shelf 60"W or 72"W
- Can be installed at a right angle or at a 15° angle

PRODUCT NO.	DEPTH	FOR SHELVES
WM27-1201	12"	WS50, WS56
WM27-1202	12"	WS51, WS52, WS53, WS57

## PARTIAL DIVIDER

SH52

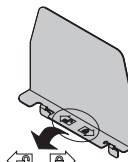

Includes pictograms for easy installation

- Unique design
- Compatible with 8"D and 12"D WM20 tiltable shelves; adjustable in 2" increments c/c
- Inserts into the shelf slots, forwards or backwards

PRODUCT NO.	D × H
SH52-1206	8" × 6"

## SLIDING DIVIDER

WS87

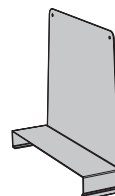

- Clips onto a 12"D WS50 steel shelf installed above or below the work surface
- Not compatible with WS58 shelf backs or front stops

PRODUCT NO.	D × H
WS87-1210	12" × 10"

# COMPONENTS – STRUCTURE ABOVE THE WORK SURFACE

## PLASTIC BIN



## RG20



- For easier storing, moving and managing of small parts
- Lightweight and durable
- 45° angled rim for easy identification of bin contents and removal of bins
- Compatible with WM55 panels for plastic bins, and WM28 / WM9C plastic bin rails
- 6" plastic bins can be subdivided

DIMENSIONS			PRODUCT NO.		
W	D	H	BIN	PARTITION	DIVIDER
3"	3"	2"	RG20-030302	-	-
4"	3"	2"	RG20-040302	-	-
6"	3"	2"	RG20-060302	RG22-0302	-
6"	6"	2"	RG20-060602	RG22-0602	RG24-0602
3"	3"	3"	RG20-030303	-	-
4"	3"	3"	RG20-040303	-	-
6"	3"	3"	RG20-060303	RG22-0303	-
6"	6"	3"	RG20-060603	RG22-0603	RG24-0603

## PLASTIC BIN RAIL

## WM28



- Hooks onto WM uprights; adjustable in 1" increments c/c
- Can be installed at a right angle or angled 15°
- Compatible with most brands of plastic bins (with hanging lip) on the market
- Compatible with all RG20 plastic bin sizes
- 75lb. capacity (evenly distributed weight)

PRODUCT NO.	WIDTH
WM28-2801	28"
WM28-3401	34"

## TOOL HOLDER

## WM30

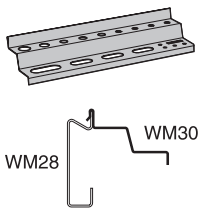

- Galvanized steel
- Installs on WM20 shelves, WM28 plastic bin rails and WM62 monitor trays
- Includes a variety of hole sizes to hang different tools

PRODUCT NO.	WIDTH
WM30-01	12"

## TOOL RAIL

## WM47

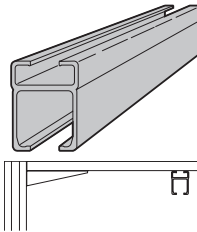

- Holds one or more WM48 balancer trolleys
- Installs on WM18 cantilever overhead supports (sold separately)
- Easily adjustable depth
- Color: black
- Load capacity: 25lb.

PRODUCT NO.	WIDTH	C/C INTERVALS
WM47-4801	48"	28" / 34"
WM47-6001	60"	28" / 34" / 56"
WM47-6002	60"	68"

## BALANCER TROLLEY

## WM48



- Inserts into the WM47 tool rail;
- Color: black;
- Can receive a pneumatic connector.

PRODUCT NO.
WM48-01

## TOOL BALANCER

## WM49

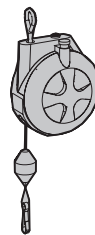

- For hanging tools over the work surface
- 6' metal cable with tension adjustment
- Color: black
- Load capacity: 3lb. max.

PRODUCT NO.
WM49-01

## JOINER FOR TOOL RAIL

## WM89

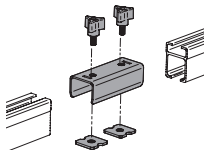

- Connects two WM47 tool rails on two adjacent workstations

PRODUCT NO.
WM89-01

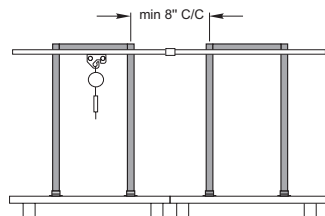



# COMPONENTS – STRUCTURE ABOVE THE WORK SURFACE

## LAMP WITH MAGNIFIER AND LED LIGHT 7000640



- Clamps onto the work surface (bracket included) or to WM uprights with a WM68-01 adapter, sold separately
- The lamp's reach on the upright can be extended with a WM69-12 arm, sold separately
- Diopter: 5 (2.25x magnification)
- Color: black

PRODUCT NO.
7000640

## PAPER AND CARDBOARD SPOOL HOLDER WM86

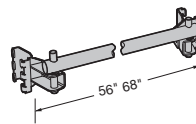

- Installs on WM uprights to create a packaging station
- Includes two end brackets and one rod
- Rod diameter: 1"
- Spool is inserted by pivoting one end of the rod, only one person needed
- Color: black
- 75lb. capacity

PRODUCT NO.	WIDTH
WM86-56	56"
WM86-68	68"

## WIRE SPOOL HOLDER WM31

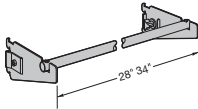

- Includes two side brackets and a 3/4" dia. rod
- Load capacity: 50lb.

PRODUCT NO.	WIDTH
WM31-2801	28"
WM31-3401	34"

## OVERHEAD LED WORKSTATION LIGHT WM43



- Installs on WM18 cantilever overhead supports (sold separately)
- Includes adapter
- Installs on single or double WM frames
- Emits a bright light while being energy efficient
- Color temperature: 6000-7000K (cool)
- Includes a 10' power cord
- To add a motion sensor, add MS to the product number, e.g., WM43-3602MS for an overhead LED workstation light with motion sensor

PRODUCT NO.	WIDTH	UPRIGHT WIDTH
WM43-3602__	36"	28" and 34" c/c
WM43-4801__	48"	28" and 56" c/c
WM43-4802__	48"	34" c/c
WM43-6001__	60"	34", 56" and 68" c/c

## VERTICAL ADAPTOR FOR ELECTRICAL AND AIR OUTLETS WM41

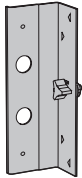

- Installs on the side of WM upright;
- Can receive a power outlet strip or pneumatic connector.

PRODUCT NO.	HEIGHT	COLOR
WM41-01	8"	Black

## LIGHT-DUTY ARM ADAPTER WM68

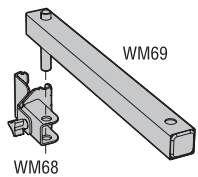

- Quick installation on WM10 uprights
- Includes a 1/2" dia. rotating rod for attaching a non-Rousseau lamp or document holder
- Load capacity: 20lb.

PRODUCT NO.	COLOR
WM68-01	Black

## LIGHT-DUTY ARM WM69



- Attaches to the WM68 light-duty arm adaptor to extend the range of a document holder or lamp pivoting on a 1/2" dia. rod
- Capacity: 20 lb.

PRODUCT NO.	WIDTH	COLOR
WM69-12	12"	Black

## DOCUMENT HOLDER WITH ARM WM70

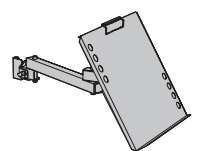

- Includes a WM68 arm adapter and a 12"W WM69 arm
- The document holder (14" x 13 1/2") includes a document clip and an edge to support binders
- Load capacity: 20lb.

PRODUCT NO.	COLOR
WM70-01	Black

# COMPONENTS – STRUCTURE ABOVE THE WORK SURFACE



WM5A

## PRIVACY PANEL

WM52



BACK-TO-BACK INSTALLATION

- Painted steel
- Closes the back of a WM bench frame
- A WM50 bracket kit must be ordered separately (one kit per panel or for back-to-back panel installation)
  - 24"H panels can be installed on 36"H and 48"H uprights
  - 36"H panels must be installed on 48"H uprights only

PRODUCT NO.	W × H
WM52-2424	24" × 24"
WM52-2436	24" × 36"
WM52-3024	30" × 24"
WM52-3036	30" × 36"

NOTES: 24"W panels must be installed on uprights 28" apart c/c  
30"W panels must be installed on uprights 34" apart c/c

## UTILITY PANEL



BACK-TO-BACK INSTALLATION

- For hanging accessories and tools
- Painted steel with perforations spaced 1" apart c/c
- Load capacity: 50lb. per panel
- Compatible with WM9F, WM9G, WM9H, WM9S and WM9L light-duty hooks, and WM9A and WM9B heavy-duty hooks
- Compatible with WM9C rails, and WM9D, WM9M, WM9N, WM9P and WM9Q holders
- Compatible with WM21 shelves
- Compatible with most popular hooks and holders on the market
- A WM50 bracket kit must be ordered separately (one kit per panel or per back-to-back panel installation)
  - 24"H panels can be installed on 36"H and 48"H uprights
  - 36"H panels must be installed on 48"H uprights only

PRODUCT NO.	W × H
WM5A-2424	24" × 24"
WM5A-2436	24" × 36"
WM5A-3024	30" × 24"
WM5A-3036	30" × 36"

NOTES: 24"W panels must be installed on uprights 28" apart c/c  
30"W panels must be installed on uprights 34" apart c/c

## PANEL BRACKET KIT

WM50



- Includes four brackets
- Required for installation of WM52, WM5A and WM54 panels
- Easy, tool-free installation on the sides of WM10 uprights

PRODUCT NO.	COLOR
WM50-01	Black



## TACKBOARD / WHITEBOARD

WM54



- Dual-function reversible panel: tack notes to a cork board or write on a lauzonite whiteboard with erasable whiteboard markers
- Panel surface is magnetic
- A WM50 bracket kit must be ordered separately

PRODUCT NO.	W × H	UPRIGHT C/C
WM54-2424	24" × 24"	28"
WM54-3024	30" × 24"	34"

## UTILITY PANEL (STRUCTURAL)

WM59

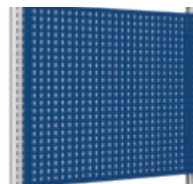

- Painted steel
- Hooks onto WM uprights
- Includes perforations spaced 1" apart c/c for hanging a range of hooks Compatible with WM9F, WM9G, WM9H, WM9J and WM9L light-duty hooks, and WM9A and WM9B heavy-duty hooks
- Compatible with WM9C rails, and WM9D, WM9M, WM9N, WM9P and WM9Q holders
- Compatible with WM21 shelves

PRODUCT NO.	W × H	UPRIGHT HEIGHT
WM59-2824	28" × 24"	36" or 48"
WM59-2836	28" × 36"	48"
WM59-3424	34" × 24"	36" or 48"
WM59-3436	34" × 36"	48"

NOTES: 28"W panels (26 holes) must be installed on uprights 28" apart c/c  
34"W panels (32 holes) must be installed on uprights 34" apart c/c

## PANEL FOR PLASTIC BINS (STRUCTURAL)

WM55

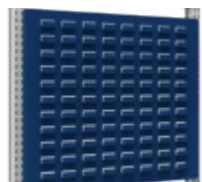

- Painted steel
- Holds RG20 Plastic Bins
- Compatible with most brands of plastic bins (with hanging lip) on the market
- Hooks onto WM uprights

PRODUCT NO.	W × H	UPRIGHTS (H)
WM55-2824	28" × 24"	36" to 48"
WM55-2836	28" × 36"	48"
WM55-3424	34" × 24"	36" to 48"
WM55-3436	34" × 36"	48"

NOTES: 28"W panels must be installed on uprights 28" apart c/c  
34"W panels must be installed on uprights 34" apart c/c

# COMPONENTS – STRUCTURE ABOVE THE WORK SURFACE

## LIGHT DUTY HOOKS



- For storing various types of parts, tools and accessories
- Compatible with all panels currently available on the market (1/4" dia. holes)
- Compatible with WM5A and WM59 utility panels

TYPE / PACKAGE	DIMENSION	PRODUCT NO.
Straight hooks/20	1 1/2"D	WM9F-150
Single hooks/20	1 1/2" dia.	WM9G-150
Single hooks/20	2" dia.	WM9G-200
Double back single hooks/10	3"D	WM9H-03
Double back single hooks/10	5"D	WM9H-05
Double back double hooks/10	3"D	WM9J-03
Double back double hooks/10	5"D	WM9J-05
Drill holder/1	5"W x 3 1/2"D	WM9L-01

NOTES: These hooks and holders are compatible with all perforated panels with 1/4" dia. holes spaced 1" apart c/c. These panels are among the most popular on the market.

## VINYL RUB-ON IDENTIFICATION DECAL WM91



- For easy identification of where tools should be stored on utility panels
- Contrasting color so it is easy to notice when a tool is missing and what kind of tool it is
- Ideal for 5S method tool management
- Sold in rolls of 2'W x 8'L

PRODUCT NO.  
WM91-01J

## SCREWDRIVER HOLDER WM9N



- Hooks onto utility panels (WM5A and WM59)
- Color: black
- Holds 6-12 screwdrivers

PRODUCT NO.	VERSION	W x D x H
WM9N-01	Single	9" x 1 1/2" x 2"
WM9N-02	Double	9" x 3 1/4" x 2"

## PLIERS HOLDER WM9M



- Hooks onto utility panels (WM5A, WM57 and WM59)
- Color: black
- Holds up to six pliers

PRODUCT NO.	W x D x H
WM9M-01	9" x 2 1/2" x 2"



# COMPONENTS – STRUCTURE ABOVE THE WORK SURFACE

## STORAGE CABINETS

### WM STORAGE CABINET

### WM75



- Hooks onto WM uprights or can be hung under the work surface
- Can be secured to the uprights with tapping screws
- The storage cabinet can be subdivided with a WM20 shelf and SH52-1206 dividers
- Load capacity: 200lb.



PRODUCT NO.	W×D×H	TYPE
WM75-281516	28" × 15" × 16"	Cabinet without door
WM75-281516L3	28" × 15" × 16"	Cabinet with door and lock (2 keys)
WM75-341516	34" × 15" × 16"	Cabinet without door
WM75-341516L3	34" × 15" × 16"	Cabinet with door and lock (2 keys)
WM76-2816L3	28" × 16" door with lock (2 keys)	

#### POSSIBLE CONFIGURATIONS

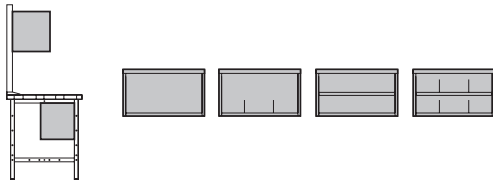

NOTE: Adjustable shelf (WM20) and dividers (SH52) sold separately.

### R CABINET HOUSING

### RD00

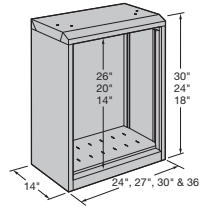

- Specially designed to be anchored to a wall or installed on WM uprights (27"W, 30"W and 36"W) with RD08 adapters
- Compatible with RD05 adjustable shelves, adjustable in 1" increments c / c
- Load capacity: 600lb. (if wall and wall anchoring are of sufficient strength)
- Includes one bottom shelf
- Wall anchoring hardware not included
- Cabinet heights available: 18", 24" and 30"
- RD08 adapters must be ordered to install 27"W, 30"W and 36"W cabinets on WM uprights
- To order: Add the cabinet height required to the product number, e.g., RD00-241424.

PRODUCT NO.	W × D
RD00-2414__	24" × 14"
RD00-2714__	27" × 14"
RD00-3014__	30" × 14"
RD00-3614__	36" × 14"

### R CABINET

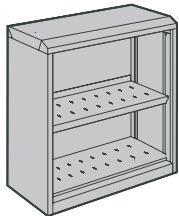

- Can be anchored to a wall or installed on WM uprights (27"W, 30"W and 36"W) with RD08 adapters
- Includes one bottom shelf
- The 30"H cabinet includes an adjustable shelf
- The shelves are compatible with SH52 dividers
- Wall anchoring hardware not included
- Choice of doors. Add one of the following to the product number:
  - 00: Without door
  - 01: Solid integrated door (except R5MEA-18\_\_)
  - 02: Polycarbonate single integrated door (for 24"H housings and over)
  - 03: Solid double integrated doors (for housings 24"H and over, and 30"W and over)
  - 04: Polycarbonate double integrated doors (for housings 24"H and over, and 30"W and over)
  - 11: Flipper door (for 18"H housings only)

HEIGHT	WIDTH×DEPTH			
	24" × 14"	27" × 14"	30" × 14"	36" × 14"
18"	R5MCA-18__	R5MPA-18__	R5MDA-18__	R5MEA-18__
24"	R5MCA-24__	R5MPA-24__	R5MDA-24__	R5MEA-24__
30"	R5MCA-30__	R5MPA-30__	R5MDA-30__	R5MEA-30__

### ADJUSTABLE SHELF

### RD05

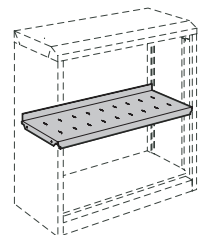

- Includes a back stop to prevent objects from falling to the bottom of the cabinet
- Adjustable in 1" increments c / c
- Load capacity: up to 100lb., evenly distributed
- Compatible with SH52 dividers

PRODUCT NO.	W × D
RD05-2412	24" × 12"
RD05-2712	27" × 12"
RD05-3012	30" × 12"
RD05-3612	36" × 12"

### ADAPTERS FOR RD00 CABINET

### RD08

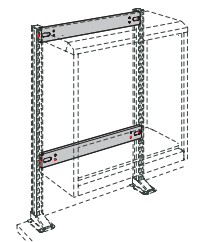

- For installing an RD00 cabinet housing (27"W, 30"W, 36"W) on WM uprights
- Easy installation

PRODUCT NO.	WIDTH
RD08-28	28"
RD08-34	34"



# COMPONENTS – STRUCTURE ABOVE THE WORK SURFACE

## SINGLE INTEGRATED DOOR FOR RD00 HOUSING

RD12 / RD13

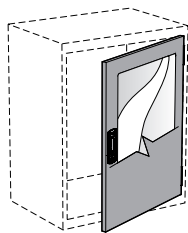

- Integrated door: RD12
- Polycarbonate integrated door: RD13
- Compatible with RD05 adjustable shelves
- Opens 180° for full access to items stored inside
- Door widths available: 24", 27", 30" and 36"
- Three types of lock available: for a standard central lock, LP for a safety hasp or L50 for an electronic lock
- To order: Specify the type & width of the door and lock required, e.g., RD12-2414\_\_.



PRODUCT NO.	HEIGHT
RD12-__14__	14" Except 36"
RD__-__20__	20"
RD__-__26__	26"

## DOUBLE INTEGRATED DOORS FOR RD00 HOUSING

RD17 / RD18

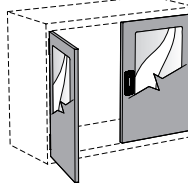

- Integrated door: RD17
- Polycarbonate integrated door: RD18
- Compatible with RD05 adjustable shelves
- Opens 180° for full access to items stored inside
- Three types of lock available: L3 for a standard central lock, LP for a safety hasp or L50 for an electronic lock
- To order: Specify the type of door and lock required, e.g., RD18-3020L3



PRODUCT NO.	W×H
RD__-3020__	30" × 20"
RD__-3026__	30" × 26"
RD__-3620__	36" × 20"
RD__-3626__	36" × 26"

## FLIPPER DOOR FOR RD00 HOUSING

RD20

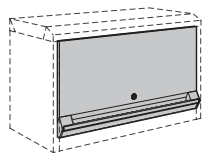

- Full-width handle provides a comfortable grip
- For 18"H wall cabinet housings only
- Two types of lock available: L3 for a standard central lock or L50 for an electronic lock
- To order an econo lock-in system, add B to the product number
- Compatible with RD05 adjustable shelves (must be factory installed)
- To order: Specify the type of lock required, e.g., RD20-2414L50



PRODUCT NO.	W×H
RD20-2414__	24" × 14"
RD20-2714__	27" × 14"
RD20-3014__	30" × 14"
RD20-3614__	36" × 14"

## LED LIGHT FOR WM CABINET

WM44

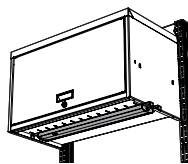

- For installation underneath a WM75 cabinet
- Emits a brighter light than fluorescent tubes and is more energy efficient
- Color temperature: 6000-7000 K (cold)

PRODUCT NO.	WIDTH
WM44-2801	28"
WM44-3401	34"



# COMPONENTS – STRUCTURE ABOVE THE WORK SURFACE

## ELECTRONICS COMPONENTS

### POWER OUTLET STRIP



- 15A power outlet strip with circuit breaker
- Mounts horizontally under a work surface or riser shelf
- Order a WM41 adapter (sold separately) for installation on WM uprights, see page 154

PRODUCT NO.	LENGTH	EXTENSION CORD	NO. OF OUTLETS
70000500	9"	6'	5, without on/off switch
70000505	12"	6'	6, with on/off switch
70000506	12"	15'	6, with on/off switch

### POWER OUTLET CHANNEL

WM40

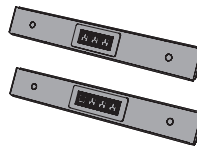

- Hooks easily onto WM uprights
- Each power outlet channel includes either three 12A outlets for 15A circuit, or three 12A outlets for 15A circuit with two USB ports
- Both versions include two knockouts for pneumatic connections
- To order: Specify the channel length required: 28" or 34"

PRODUCT NO.	OPTIONS
WM40-__1001	3 power outlets (12A), 2 knockouts for pneumatic connections
WM40-__1101	3 power outlets (12A), 2 knockouts for pneumatic connections, 1 plate
WM40-__1201	3 power outlets (12A), 2 USB ports, 2 knockouts for pneumatic connections
WM40-__1301	3 power outlets (12A), 2 USB ports, 2 knockouts for pneumatic connections, 1 plate

### GROUNDING CORD

WS89

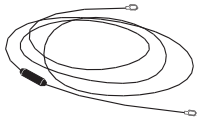

- Connects a shelf or dissipative top to a grounding block or directly to the ground
- Dissipates electrical charges that can damage electronic components
- Length: 10'

PRODUCT NO.	
70000300	Grounds a workstation 1MΩ resistance
WS89-01	Connects all components on the workstation to a common grounding point

### GROUNDING BLOCK

70000350

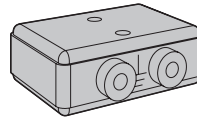

- Two jacks to connect grounding wrist straps
- Includes a 10' grounding cord
- Dissipates electrical charges that can damage electronic components

PRODUCT NO.
70000350

### GROUNDING WRIST STRAP

70000320

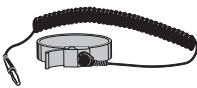

- Made of stretch fabric
- 6' cable
- Dissipates electrical charges that can damage electronic components
- 1MΩ resistance

PRODUCT NO.
70000320



### CONDUCTIVE PLASTIC BIN



RG21

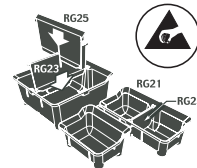

- Dissipates electrical charges that can damage electronic components
- Color: black
- For easier storing, moving and managing of small parts
- Lightweight and durable
- Compatible with WM55 panels for plastic bins, WM28 plastic bin rails and all 3"H and 4"H drawers
- 45° angled rim for easy identification of bin contents and removal of bins
- 6" plastic bins can be subdivided

DIMENSIONS			PRODUCT NO.		
W	D	H	BIN	PARTITION	DIVIDER
3"	3"	2"	RG21-030302	-	-
4"	3"	2"	RG21-040302	-	-
6"	3"	2"	RG21-060302	RG23-0302	-
6"	6"	2"	RG21-060602	RG23-0602	RG25-0602
3"	3"	3"	RG21-030303	-	-
4"	3"	3"	RG21-040303	-	-
6"	3"	3"	RG21-060303	RG23-0303	-
6"	6"	3"	RG21-060603	RG23-0603	RG25-0603

Since 1961

# INDUSTRIAL SHELVING SYSTEMS

For over 60 years, Rousseau, an established manufacturer of storage systems, has perfected superior quality products with great reliability. With a dynamic team and terrific service, we proudly offer our clientele a solution adapted to their own unique needs. We offer a one-stop shopping experience while creating a one-of-a-kind solution made to fit every space and meet every storage challenge.

Our high-tech engineering allows us to offer great versatility and systems that are easy to install, aesthetic and convenient to work with. Each and every aspect of our decision making process is based on what our clients need. Rousseau storage systems are distinctive with personalized touches based on custom accessories and infinite modularity.



## Healthcare Storage Solutions make the most of every inch of your hospital:

Rousseau products improve inventory efficiency while storing more in a small space.

- Keep Expansive Instruments Secure and Clean;
- Enhance Productivity;
- Maximize Your Space;
- Facilitate Inventory Management;
- Create a Sophisticated and Superior Image.



## A One-Stop Solution for your Medical Center:

Items ranging from surgical kits to linens can all be stored with the Rousseau Storage System.

- Sterile Processing Department;
- Central Sterile Supply;
- Biomedical Department;
- Central Store Room and Distribution Center;
- Maintenance Department;
- And much more...

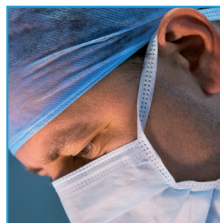

# Sterile Processing Department

Rousseau storage systems perfectly meet all of the specific needs for hygiene and cleanliness that your department insists upon. Our modular cabinets, with the numerous accessories available, offer you the possibility of storing your supplies and materials in the correct place and away from any contaminants. With the many drawers dimensions and layouts available, you have the opportunity to customize your storage solutions.

Our workstation systems provide you with ergonomic work environment solutions while providing a polished look at the same time. With options like stainless steel tops and storage cabinets for above the work surface with the Rousseau multifunctional support, we can offer you a unique solution that is adapted to your specific needs in the sterilization department.

## ISS BENEFITS

- Ergonomically designed to improve your productivity while packing surgical kits;
- All your instruments stored at the right place decreases retrieval times;
- Clean and safe environment for your instruments, medications and supplies.



R5WH5-6006





# Central Sterile Supply

Rousseau storage solutions are perfectly adapted to the sterilized materials supply room. With all of the essential materials and supplies that are stored in your department and are required for good patient care, we are looking to provide you with storage solutions that will allow you to quickly and easily find the materials you are looking for.

In addition, we offer many different solutions that are adapted to your everyday reality. We know that available space is sometimes limited; that's why we offer a shelving system with integrated drawers allowing you to recuperate up to 70% of your floor space. Rousseau Spider® shelving systems have many different accessories and characteristics that will allow you to maximize your efficiency and your central supply room for sterilized materials. Our multitude of accessories allows you to have the most diversified storage solution on the market.

## ISS BENEFITS

- Secure and dust free storage for your sterile supplies with our lockable glass doors and drawers;
- Easy and quick retrieval of your surgical kits with our 100% opening roll-out trays and drawers;
- Easily find your sterile supplies with our glass doors and partitioning and labeling options.



R5SSE-874802



# Biomedical Department

With your department being in charge of repairing medical equipment for the entire hospital, it is important to be well equipped to perform your duties. From the smallest tool to the largest piece of equipment that needs to be repaired, it is important that your work space be well organized with quick and easy access to your tools. The Rousseau workstation system provides excellent modularity. Over 200 components offered in different dimensions allow you to create your own personalized workstation.

Rousseau modular cabinets are also an essential part of being well organized. Stationary cabinets allow you to store each of your tools in the right place. Mobile cabinets are very useful when the time comes for performing repairs on large equipment that cannot be moved. This is how we create a customized solution to meet the needs of your department. No matter how large or small your biomedical department is, we have a solution for every situation.

## ISS BENEFITS

- Personalized workstation for your needs – for whatever equipment or tools you are repairing;
- Moveable station – by rolling the Rousseau “L” Compact Mobile Cabinet with soft casters in the hospital for maintenance of larger equipment;
- Keep everything organized and within hand reach while repairing your medical equipment.



L3BBD-4006L3

LC3001





## Central Store Room and Distribution Center

Rousseau storage solutions are adapted to the needs of the central store room and distribution center of your hospital. Your department is responsible for receiving, sorting and distributing equipment as well as medical and surgical supplies; you are looking for a storage system that allows you to recuperate as much floor space as possible. The customized solutions that we offer will give you the chance to regain space and time while meeting the needs of your entire department.

You will have a perfectly functional and integrated solution thanks to the Spider® Shelving System – no matter the size and shape of the items you need to store. For smaller supplies, the modular drawer is the ideal solution. **ISB, Benefits** and roll-out shelves are the perfect option for larger, bulkier items. Rousseau storage systems are an all-in-one solution for your department!

- Recover up to 70% of your space by using Rousseau drawers in shelving;
- Save a considerable amount of time by finding all your items quickly thanks to our partitioning and labeling accessories;
- Store all of your items, from printer ink cartridges to medical devices, in one shelving system.



SRE9005



# Maintenance Department

Supervising the buildings and outdoor spaces as well as performing equipment maintenance requires storing all of the materials and components that you use at the hospital. The storage solutions that Rousseau offers will help you to maximize your storage.

Whether you choose shelving or cabinets, the Rousseau drawer has a 400 lb capacity. Durable and high performance, our drawer has a lifetime warranty on the rolling mechanism. Whatever your specific needs may be, we have the solution for your maintenance department.

## ISS BENEFITS

- Unlimited ways to configure your drawers – for any shape and sized parts;
- Durable and High-Capacity Products that will last for generations without any signs of wear;
- Condense all your items in to the right place to facilitate inventory and save space in your hospital.







## COLORS

### Standard Colors

Avalanche Blue 055	Everest Blue 051	Classic Blue 052	Midnight Blue 057	Glossy Sapphire Blue 560	Boreal Green 102	Glossy EverGreen 1015	Black 091	Glossy Black 902	Beige 041
Frost White 061	Light Gray 071	Charcoal Gray 072	Glossy Yellow 208	Sienna Orange 085	Flame Red 081	Glossy Carmine Red 806	White 616	055 / 061	051 / 071

### Handle End Caps and Door Handle



The colors may differ slightly from those illustrated.

Note: For custom colors, contact our customer service representatives.



Since 1961  
**INDUSTRIAL**  
**SHELVING SYSTEMS**

**Industrial Shelving Systems**  
 455 E. Elliott Ave.  
 St. Louis, MO 63122  
[www.IndustrialShelving.com](http://www.IndustrialShelving.com)  
 Telephone : 314-965-6500  
 Fax : 314-965-4500  
 E-mail : [info@industrialshelving.com](mailto:info@industrialshelving.com)